

## Instrument Cluster Removal Guide

### Ascender, Envoy, Ranier, Trailblazer

1. Apply the parking brake.
2. Turn the ignition on, but do not start the vehicle.
3. Depress the brake pedal and shift the transmission all the way back to 1st gear.
4. Remove the phillips screw #1 in the diagram below.
5. Return the transmission to park and turn the ignition off.
6. Remove the 2 screws inside the instrument cluster area. (#2 below)
7. Remove the plastic caps and 2 bolts from the trim panel below the steering wheel.
8. Tilt down the trim panel to access and remove the 3 screws at the bottom of the instrument trim panel. (#3 below)
9. Tilt the steering wheel as far down as possible.
10. Carefully pull out the trim panel as pictured below, disconnecting any wires, if applicable.
11. Remove the 4 screws holding the instrument cluster in place.
12. Carefully pull out the instrument cluster and unplug the wiring harness on the back.

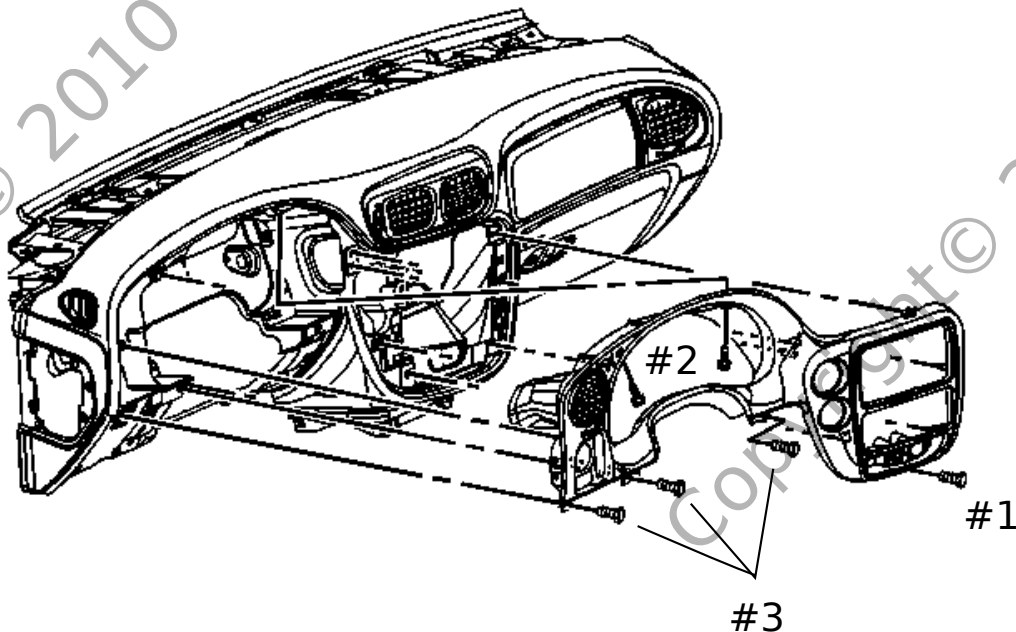

**Disclaimer of Liability:** These instructions are provided free of charge as reference only to assist in the removal of your instrument cluster. No warranty or guarantee is provided for these instructions, and Circuit Board Medics LLC cannot vouch for completeness or accuracy. Use of the instructions is conducted at the user's risk. Circuit Board Medics LLC is not liable for and hereby excludes any and all indirect, incidental, special, or consequential damages related to the use of information contained in this instructional guide. If you have information that can be modified, added, or deleted to these instructions to help with completeness or accuracy, we welcome your feedback.