

Instrument Cluster Removal Guide

Avalanche, Escalade, Sierra, Silverado,
Suburban, Tahoe, Yukon

1. Apply the parking brake to prevent the vehicle from moving.
2. Turn ignition on, but do not start vehicle.
3. Depress brake pedal and shift transmission into 1st gear (lowest) position.
4. Tilt the steering wheel down as far as possible.
5. Remove the instrument trim piece as shown below.
6. Remove the 4 screws holding the instrument cluster in place.
7. Carefully pull out the instrument cluster and unplug the wiring harness on the back.

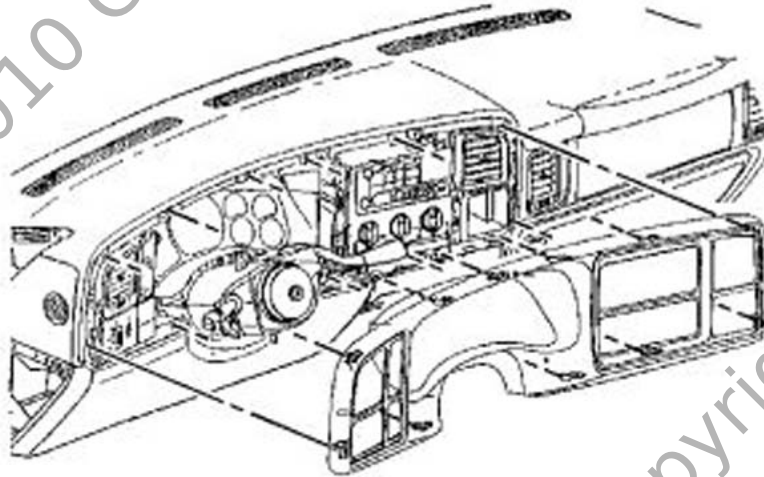

Disclaimer of Liability: These instructions are provided free of charge as reference only to assist in the removal of your instrument cluster. No warranty or guarantee is provided for these instructions, and Circuit Board Medics LLC cannot vouch for completeness or accuracy. Use of the instructions is conducted at the user's risk. Circuit Board Medics LLC is not liable for and hereby excludes any and all indirect, incidental, special, or consequential damages related to the use of information contained in this instructional guide. If you have information that can be modified, added, or deleted to these instructions to help with completeness or accuracy, we welcome your feedback.