

Instrument Cluster Removal Guide

Monte Carlo

1. Remove ignition switch trim with a small flat screwdriver.
2. Remove the fuse access panel on the drivers side and remove the dash screw located inside.
3. Open the glove compartment and remove the screw holding the dash trim in place.
4. With the parking brake on, turn the vehicle ignition on, (do not start the engine) depress the brake pedal, and shift the transmission all the way back into 1st gear. (this gives you room to remove the dash trim piece)
5. Carefully pull out the dash trim piece as shown below, being careful with any wires that are still connected.
6. Disconnect the hazard lights button and any other electrical connections.
7. Remove the dash trim piece.
8. Remove the 4 screws holding the instrument cluster in place.
9. Remove the instrument cluster and disconnect the wiring harness.

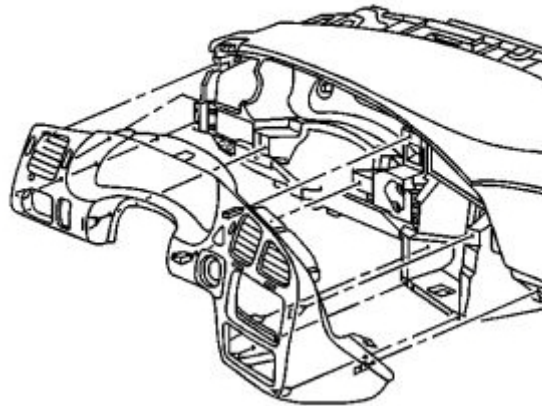

Disclaimer of Liability: These instructions are provided free of charge as reference only to assist in the removal of your instrument cluster. No warranty or guarantee is provided for these instructions, and Circuit Board Medics LLC cannot vouch for completeness or accuracy. Use of the instructions is conducted at the user's risk. Circuit Board Medics LLC is not liable for and hereby excludes any and all indirect, incidental, special, or consequential damages related to the use of information contained in this instructional guide. If you have information that can be modified, added, or deleted to these instructions to help with completeness or accuracy, we welcome your feedback.