

Instrument Cluster Removal Guide

Impala

1. With a small, flat-bladed screwdriver, remove the trim from around the ignition switch.
2. Remove the trim piece on the right side of the dash to access screw #1 below.
3. Remove screw (A) pictured below.
4. Repeat steps 2 and 3 on the left side of the dash. (B below)
5. Remove the 2 screws above the instrument area. (C below)

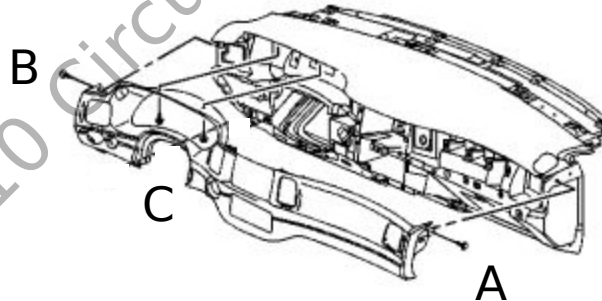

6. Apply the emergency brake, and depress the brake pedal.
7. Turn the ignition on, but do not start the vehicle.
8. Shift the transmission all the way back to 1st gear.
9. Tilt the steering wheel down as far as possible.
10. Carefully pull out the instrument trim panel and disconnect any wires, if applicable.
11. Remove the instrument trim panel as shown above.
12. Remove the 4 screws holding the instrument cluster in place.
13. Carefully pull out the instrument cluster and unplug the wiring harness on the back.

Disclaimer of Liability: These instructions are provided free of charge as reference only to assist in the removal of your instrument cluster. No warranty or guarantee is provided for these instructions, and Circuit Board Medics LLC cannot vouch for completeness or accuracy. Use of the instructions is conducted at the user's risk. Circuit Board Medics LLC is not liable for and hereby excludes any and all indirect, incidental, special, or consequential damages related to the use of information contained in this instructional guide. If you have information that can be modified, added, or deleted to these instructions to help with completeness or accuracy, we welcome your feedback.